

BERM BREAKWATERS: DESIGNING FOR WAVE HEIGHTS FROM 3 M TO 7 M

Jentsje van der Meer¹ and Sigurdur Sigurdarson²

ABSTRACT

Berm breakwaters may be a good alternative for rock armoured slopes and even concrete armoured slopes or breakwaters. Guidance on berm breakwater design, including large rock quarrying, was lacking as this type of breakwater does not belong to the conventional designs of rock and concrete armour. Some guidance by the authors became available in recent years in conference papers and that all has resulted in a book on berm breakwaters. This paper considers the actual geometrical design of a number of berm breakwaters, depending on available rock sizes as well as on the design wave climate. Three wave climates are taken, 3 m, 5 m and 7 m. For each wave climate various maximum rock classes are considered, which in reality will depend on availability of such rock, and different designs presented. For the 3 m and 5 m wave climate the designs have been compared with a conventional two-layer design. All these designs together give a good impression of what can be achieved by a proper berm breakwater design.

INTRODUCTION

The design of modern berm breakwaters started more or less in 1983 by Baird & Associates in Canada. The original design consisted of mass armoured berms that were reshaped to statically stable S-shaped slopes. The design was adopted in Iceland and eventually led to a development with more stable structures by utilizing available rock sizes, large rock and more gradings. This more stable and only partly reshaping structure is called the Icelandic-type berm breakwater.

Real guidance on design and construction of berm breakwaters was lacking, but the new book of both authors may be seen as an improvement on this, Van der Meer and Sigurdarson (2016). Aspects of this book were presented at various conferences:

- New classification of berm breakwaters, Sigurdarson and Van der Meer (2012)
- Recession, wave overtopping and reflection, Sigurdarson and Van der Meer (2013)
- Geometrical design of the cross-section, Van der Meer and Sigurdarson (2014)
- Application of geometrical design rules, Sigurdarson *et al.* (2014)
- Quarries and rock grading, Sigurdarson and Van der Meer (2015)

This paper uses the many formulae on geometrical design of the cross-section as described in Van der Meer and Sigurdarson (2014). The formulae have not been repeated here, but equation numbers in that paper are used here for reference.

"Rock" is the essential word in design of berm breakwaters. Often dedicated quarries can be found and opened to produce the required rock. This is different from designs with rock demand from existing quarries, where delivery of very large rock classes may be problematic. It has been proven possible to go for really large rock in dedicated quarries and all this experience has been described in the book. Quarry and project management as well as blasting and sorting techniques are essential in getting all required rock for an acceptable price. And this is also true for developing countries. Berm breakwaters may be an alternative for conventional two-layer rock slopes as well as for application of concrete units. It depends mainly on rock availability and design wave conditions. This paper gives ten cross-sections or designs for design wave heights ranging from 3 m to 7 m.

INTRODUCTION TO EXAMPLES OF DESIGNS

The geometrical design method of Van der Meer and Sigurdarson (2014) has been used to present a conceptual cross-section. Assessment of this cross-section by Sigurdarson has led to the final design of the cross-section. Three wave climates have been considered, a very moderate wave climate with $H_{SD} = 3$ m, a quite normal wave climate with $H_{SD} = 5$ m and an extreme wave climate with $H_{SD} = 7$ m. Standard rock gradings have been chosen up to the maximum of 10-15 t, as well as gradings from dedicated quarries, starting from 0.5-2 t up to very large gradings of 10-20 t and even 20-35 t.

¹ UNESCO-IHE, Delft, and Van der Meer Consulting bv, Akkrum, The Netherlands, j.vandermeer@unesco-ihe.org

² IceBreak, Reykjavik, Iceland, sigurdur.sig@simnet.is

Classification of berm breakwaters

Berm breakwaters can be divided into hardly reshaping (HR), partly reshaping (PR) and fully reshaping (FR), all depending on the stability number for the (100-years) design condition, H_{SD} . A berm breakwater can be designed as a mass armoured berm breakwater (MA) or an Icelandic-type berm breakwater. The classification is given in Table 1, where S_d is the damage number and Rec the expected recession of the berm.

Type of breakwater	Abbreviation	$H_{SD}/\Delta D_{n50}$	S_d	Rec/D_{n50}
Hardly reshaping berm breakwater (Icelandic-type)	HR-IC	1.7-2.0	2-8	0.5-2
Partly reshaping Icelandic-type berm breakwater	PR-IC	2.0-2.5	10-20	1-5
Partly reshaping mass armoured berm breakwater	PR-MA	2.0-2.5	10-20	1-5
Reshaping berm breakwater (mass armoured)	FR-MA	2.5-3.0	--	3-10

Table 1: Classification of berm breakwaters

Design wave climate and example gradings

There are differences between rock coming from a dedicated quarry and standard gradings as described in the Rock Manual (2007), see also Sigurdarson and Van der Meer (2015). The maximum standard grading is 10-15 t, whereas it is often possible to get much larger rock, even classes like 20-35 t, from dedicated quarries.

The type of berm breakwater with its expected behaviour has been described in Table 1 and is mainly depending on the stability number. The kind of berm breakwater that can be designed depends further on the available (maximum) rock class and of course on the design wave height, H_{SD} . In order to come to useful examples some elementary data have been gathered in Table 2.

Firstly, possible rock classes from a dedicated quarry are being used, based on earlier experience (see Sigurdarson and Van der Meer (2015)) and secondly the heavy standard gradings as given in the Rock Manual (2007). Then three wave climates have been considered, a very moderate wave climate with $H_{SD} = 3$ m, a quite normal wave climate with $H_{SD} = 5$ m and an extreme wave climate with $H_{SD} = 7$ m. Table 2 gives the calculated stability numbers for each chosen rock class (except for underlayers) and for each wave climate, considering a mass density of the rock of 2700 kg/m^3 and of sea water 1025 kg/m^3 . Actual stability numbers may change with other mass densities.

		Stability number $H_{SD}/\Delta D_{n50}$		
Dedicated quarry	M_{50} (t)	$H_{SD} = 3$ m	$H_{SD} = 5$ m	$H_{SD} = 7$ m
Class 20-35 t	25.0	0.87	1.46	2.04
Class 10-20 t	15.0	1.04	1.73	2.42
Class 4-10 t	7.0	1.34	2.23	3.12
Class 1-4 t	2.5	1.88	3.14	4.39
Class 0.2-1 t	underlayer			
Class 2-6 t	4.0	1.61	2.68	3.76
Class 0.5-2 t	1.2	2.41	4.01	5.61
Standard gradings				
Class 10-15 t	12.5	1.10	1.84	2.57
Class 6-10 t	8.0	1.28	2.13	2.98
Class 3-6 t	4.5	1.55	2.58	3.61
Class 1-3 t	2.0	2.03	3.38	4.73
Class 0.3-1 t	underlayer			

Table 2: Stability numbers for chosen rock classes and design waves. Grey cells give the examples described in this paper.

Stability numbers smaller than $H_{SD}/\Delta D_{n50} < 1.7$ mean that a hardly reshaping berm breakwater can (easily) be made. That is the case for most of the heavy rock classes and a design wave height of 3 m. For a wave height of 5 m, such small stability numbers can only be reached with a Class I rock of 20-35 t (giving $H_{SD}/\Delta D_{n50} = 1.46$). This low stability number cannot be reached for a design wave height of 7 m. Stability numbers $H_{SD}/\Delta D_{n50} > 3.0$ mean that the structure would become dynamically stable and this is not acceptable for a berm breakwater. Mainly the smaller gradings and for design wave heights of 5 m and more show these large stability numbers.

The most interesting cases in Table 2 are stability numbers between $H_{SD}/\Delta D_{n50} 1.7 - 3.0$. They give the area of the design of berm breakwaters. These numbers are bold figures in the table. But some stability numbers for the same design wave height are quite similar, mainly because some of the gradings for a dedicated quarry have been chosen quite similar to the heavy standard gradings in the Rock Manual (2007). For this reason examples have been chosen from Table 2 in such a way that, if possible, all three types (hardly, partly and fully reshaping) are present for each design wave height and they are distributed over the rock classes for dedicated quarries as well as the heavy standard gradings. The cells with a gray colour are the examples that will be described in the next sections.

For a design wave height of only 3 m, it is not necessary to design a fully reshaping mass-armoured berm breakwater. Already with a Class I of 0.5 – 2 t it is possible to design a partly reshaping berm breakwater. In total eight combinations of H_{SD} and rock class have been chosen from Table 2.

Conceptual design by applying geometrical design rules

Figure 1 shows the principal cross-section of an Icelandic-type berm breakwater with the main geometrical design parameters as described in Van der Meer and Sigurdarson (2014). With only wide graded, or preferably two narrower rock classes in the berm, it becomes the mass-armoured breakwater. The geometrical design means that the parameters in Figure 1 have to be established. As most of them have been given in formulae it is quite easy to make a spreadsheet and calculate the parameters automatically. Then design choices can be made and a conceptual cross-section can be drawn, also in the same spreadsheet (available at www.vdm-c.nl). The outcome may need further modification and will finally result in the design drawing of the breakwater cross-section.

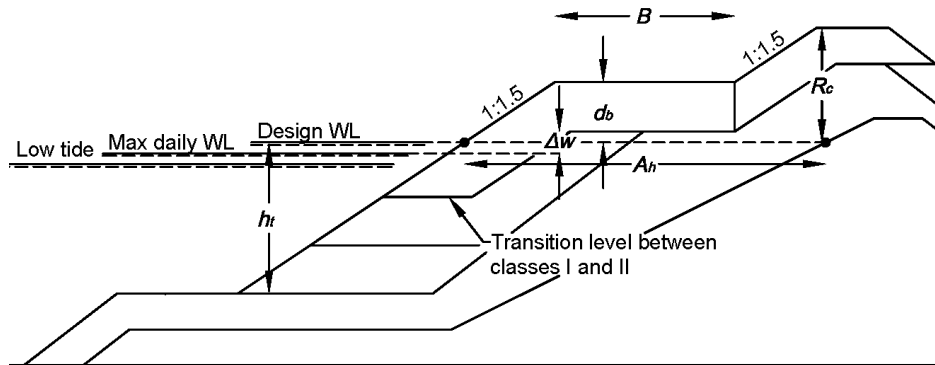

Figure 1: Principal cross-section of an Icelandic-type berm breakwater with the main geometrical design parameters.

The developed spreadsheet will be described here in depth and will then be used for all examples given in this paper, without further explanation of the spreadsheet. The first part gives the general design conditions as given in Table 3. A grey cell means that it is a requirement to give this item a (design) value. Design wave heights have to be given, the H_{SD} for the 100-years return period and the overload condition, which could be about 20% higher, or based on a much longer return period. In this way a performance-based design is achieved. Design water levels have to be given, as well as the wave height associated with a low water level. Finally, allowable overtopping has to be given for both design conditions, as well as mass densities of rock and water.

The next item is the specification of rock classes that are foreseen for the berm of the breakwater, see Table 4. After first calculations or a changed quarry yield prediction or output, it might be possible that this input will change and lead to a slightly adjusted cross-section. Two rock classes should be specified for a mass-armoured berm breakwater, leaving a blank in the two lowest cells, and three classes for an Icelandic-type berm breakwater. One may give the 0% and 100% class limits, as often done for the Icelandic-type designs, but also the limits as given for the standard heavy gradings in the

Rock Manual [2007]. These are NLL <10% and NUL > 70%, where NLL and NUL describe the class boundaries.

<i>General conditions</i>			<i>Remarks</i>
Design wave height H_{SD}	5	m	100-years return period
Peak period T_p	10.3	s	
Overload H_s	6	m	About 1.2 H_{SD}
Design water level DWL	2	m CD	
Lowest water level with H_{SD}	1	m CD	
Lowest storm level	0	m CD	
H_s at lowest storm level	4.5	m	
Mean High Water Spring	1	m CD	
Bottom level of foreshore at toe of structure	-10	m CD	
Allowable overtopping q for H_{SD}	1	l/s per m	
Allowable overtopping q for overload	10	l/s per m	
Mass density water	1025	kg/m ³	
Mass density rock	2700	kg/m ³	

Table 3: General conditions in the design spreadsheet (www.vdm-c.nl). Grey cells are inputs required by the user.

<i>Choice of rock classes</i>		
Rock Class I: minimum mass (0-10%)	5	t
Rock Class I: maximum mass (70-100%)	10	t
Rock Class II: minimum mass (0-10%)	1	t
Rock Class II: maximum mass (70-100%)	5	t
Rock Class III: M_{min} (leave open for MA)	0.3	t
Rock Class III: M_{max} (leave open for MA)	1	t

Table 4: Rock classes to be specified in the design spreadsheet

All data specified in Tables 3 and 4 lead to the first outcome, mainly on related parameters and the type of berm breakwater. An overall view is given in Table 5. The wave steepness has been calculated, as well as M_{50} 's or D_{n50} 's, where these are based on the middle of the class limits. For example the Class I 5-10 t armourstone has $M_{50} = 7.5$ t, with an associated $D_{n50} = 1.41$ m. This leads to a stability number $H_s/\Delta D_{n50}$ for design conditions and consequently to the characteristics of the berm breakwater: hardly, partly or fully reshaping (based on Table 1).

The basic recession has been calculated, based on equations for the design condition and overload condition, respectively, given in Van der Meer and Sigurdarson (2014). This is a basic recession as not all possible influences on recession, positive as well as negative, have yet been taken into account.

The berm width of a berm breakwater is closely related to the expected recession, but even more on the wanted resiliency, see Table 6 and Van der Meer and Sigurdarson (2014). Small expected recession gives a large resiliency and vice versa. It is a designer's explicit choice how resilient he or she wants to design the berm breakwater. There is a relationship between the expected recession and resiliency, but the resiliency is given as a range. This is 10-20% for a hardly reshaping berm breakwater, 20-40% for a partly reshaping and less than 70% for a fully reshaping berm breakwater. The percentage is the part of the berm that might be eroded by the design wave height H_{SD} . A measure for the berm width can then be calculated, where also a minimum berm width based on a required minimum number of stones (geometry) should be considered, see Van der Meer and Sigurdarson (2014).

<i>Outcome of main parameters</i>			<i>Remarks</i>
Wave steepness s_{op}	0.030	-	
Relative mass density Δ	1.63	-	
Median mass Class I M_{50}	7.5	t	Middle of the class limits
Nominal diameter Class I D_{n50}	1.41	m	
Stability number $H_{SD}/\Delta D_{n50}$	2.18	-	
Type of berm breakwater	Partly reshaping		Table 1
Number of rock classes for berm	3		
Basic recession for H_{SD} (no adaptation)	3.38	m	*Equation 3-5
Recession for overload (no adaptation)	6.08	m	**Equation 3.20
Nominal diameter Class II, D_{n50}	1.04	m	Middle of the class limits
Nominal diameter Class III, D_{n50}	0.62	m	Middle of the class limits

Table 5: Outcome of main parameters in the design spreadsheet.
*Van der Meer and Sigurdarson (2014); **Van der Meer and Siigurdarson (2016)

<i>Resiliency, berm width and level</i>			<i>Remarks</i>
Wanted resiliency	30	%	*Equations 3-5
Resulting Berm width B from resiliency	11.26	m	*Equation 6
Minimum berm width B_{min} from geometry	4.78	m	*Equation 7
Berm level $0.6 H_{SD}$	5	m CD	*Equation 11
Δw for waves during construction	1	m	Safety measure
MHWS plus Δw = working level	2	m CD	
Minimum berm level from construction	4.81	m CD	Above level + 2 D_{n50} Class I
Design choice of berm width	12.00	m	
Design choice of berm level	5.00	m CD	

Table 6: Berm width and level, based on resiliency, as in the design spreadsheet.
*Van der Meer and Sigurdarson (2014)

The berm level is a free choice, but a berm level above a certain value ($\geq 0.6 H_{SD}$) increases stability and reduces recession, see Van der Meer and Sigurdarson (2014). Therefore this level is given to base a final design choice on. In Table 6 this comes to a level of +5 m CD. A minimum berm width follows from the construction procedure if one wants to construct Class I rock by working on the top level of the Class II rock and take into account some safety with regard to frequent waves. This safety is given by Δw and must be related to expected frequent wave conditions during construction. This safety is put on top of the level for MHWS. It results in a minimum berm level, in the example in Table 6 this is +4.81 m CD.

Based on the outcome in Table 6, the designer has to make two design choices: the berm width and the berm level. The final berm width may also depend on the application of positive and negative influences, see Van der Meer and Sigurdarson (2014) and is chosen here as 12.0 m. The final berm level can be based on the two calculated levels and here the highest level is chosen to have the positive influence of a high berm level on recession: 5.0 m CD.

The horizontal armour width, A_h , determines more or less the volume of large rock in the berm, see Figure 1. The minimum horizontal armour width is given by Equation 10 in Van der Meer and Sigurdarson (2014) and has been calculated in Table 7. The designer's choice in is quite similar.

Required horizontal armour width A_h	21.8	m	*Equation 10
Design choice of A_h	22.0	m	

Table 7. Horizontal armour with A_h in the design spreadsheet. *Van der Meer and Sigurdarson (2014).

The transition from Class I to Class II rock at the seaward slope should not be too high, as the Class II rock will result in more recession to the structure if this rock is attacked by waves. Sigurdur and Van der Meer (2014) give some guidance. One could consider the lowest possible water level with the design wave height H_{SD} , as well as a lower water level with a little smaller wave height. For an Icelandic-type berm breakwater with at least three rock classes in the berm, the highest level of transition is $0.4 H_s$ below the water level considered and for a mass-armoured berm breakwater with two classes this may be $0.6 H_s$. Table 8 gives the calculation and the designer has to make a final choice on the level.

<i>Minimum transition level to Class II</i>	<i>Remarks</i>		
For H_{SD} at lowest level	-1.0	m CD	$0.4 H_{SD}$
For lowest level with according H_s	-1.8	m CD	$0.4 H_s$
Design choice of transition for IC (3 rock classes)	-1.8	m CD	
Transition lower class for MA (2 rock classes)	-2.7	m CD	$0.6 H_s$

Table 8: Transition level from Class I to Class II as in the design spreadsheet

The crest level design of a berm breakwater depends very much on what wave overtopping should be allowed. Based on the analysis of tested berm breakwaters (Sigurdarson and Van der Meer (2013)) most berm breakwaters had a crest level 1.2 to $1.4 H_{SD}$ above design water level. These limits have first been calculated in Table 9. But if an allowable overtopping discharge has been given, the required influence factor γ_{BB} can be calculated and subsequently the required crest level by the design equation on wave overtopping. Perpendicular wave attack has been assumed.

<i>Crest level ($\gamma_\beta = 1$)</i>	<i>Remarks</i>		
If no overtopping criteria, $R_{c \min}$	8.0	m CD	*Equation 8
If no overtopping criteria, $R_{c \max}$	9.0	m CD	*Equation 8
For given allowable overtopping, q , γ_{BB}	0.42		**Equation 4.13-4.15
Required crest level for design conditions	9.92	m CD	**Equation 4.13-4.15
Required crest level for overload	9.64	m CD	**Equation 4.13-4.15
Design choice of crest level	10.00	m CD	

Table 9: Crest level calculations as in the design spreadsheet. *Van der Meer and Sigurdarson (2014). **Van der Meer and Sigurdarson (2016).

The wave overtopping equations in Van der Meer and Sigurdarson (2014) are based on EurOtop (2007). The update of this manual, EurOtop (2016) presents new overtopping equations, which for berm breakwaters have been used in Van der Meer and Sigurdarson (2016). Therefore one is referred to this manual and book for the updated overtopping equations.

Equation 4.13 in Van der Meer and Sigurdarson (2016) on wave overtopping gives a *design approach* with some safety on the outcome (about one standard deviation more). This safe design is proposed as prediction of wave overtopping is quite uncertain. The influence factor γ_{BB} is different for partly and hardly reshaping berm breakwaters (Equations 4.14) and fully reshaping berm breakwaters (Equation 4.15). The official transition between the types is at $H_s/\Delta D_{n50} = 2.5$ and by using the two equations gives a discontinuity at this transition. In order to avoid a discontinuity, the crest levels in Table 9 have been calculated with Equation 4.14 if $H_s/\Delta D_{n50} < 2.3$ and with Equation 4.15 if $H_s/\Delta D_{n50} > 2.6$. For $2.3 \leq H_s/\Delta D_{n50} \leq 2.6$ both equations have been used and the crest levels have been interpolated. At the lowest row in Table 9, the designer has to make a choice on the crest level.

Figure 1 shows a foundation level for the large rock classes of an Icelandic-type berm breakwater, well above the level of the seabed. In the graph this is given as Class IV on a horizontal layer. For relatively deep water as well as for depth-limited conditions it is favourable for the stability of the berm if this foundation level is as high as possible, see also Van der Meer and Sigurdarson (2014). In principle one could consider this structure as a toe berm structure for a conventional breakwater and

EXAMPLES FOR A DESIGN WAVE HEIGHT OF 5 M

HR IC dedicated quarry, Class I 10-20 t

The design condition is a design wave height of $H_{sD} = 5.0$ m with a wave steepness of $s_{op} = 0.03$, giving $T_p = 10.3$ s. The overload condition is considered to be 20% higher than the design condition, giving $H_s = 6.0$ m at the design water level DWL. Tides range between 0 m CD to + 1 m CD (1 m tidal range). The design water level (100-years condition) = surge + maximum tide = +2 m CD. Daily waves are quite moderate and a safety margin of $\Delta w = 1$ m above MHS will be enough for construction. A more or less flat foreshore is present and at the toe of the structure the bottom is present at -10 m CD. All input and calculated values, including design choices, are given in the spreadsheet in Appendix D of Van der Meer and Sigurdarson (2016) and have not been repeated here.

The stability number is calculated as $H_s/\Delta D_{n50} = 1.73$ for a Class I of 10-20 t, which indeed gives a hardly reshaping berm breakwater. The rock grading comes from a dedicated quarry. For this Class I one can choose connecting classes as Class II = 4-10 t, Class III = 1-4 t and if necessary a Class IV = 0.2-1 t, all given in Table 2. Here three classes are chosen, see Figure 3.

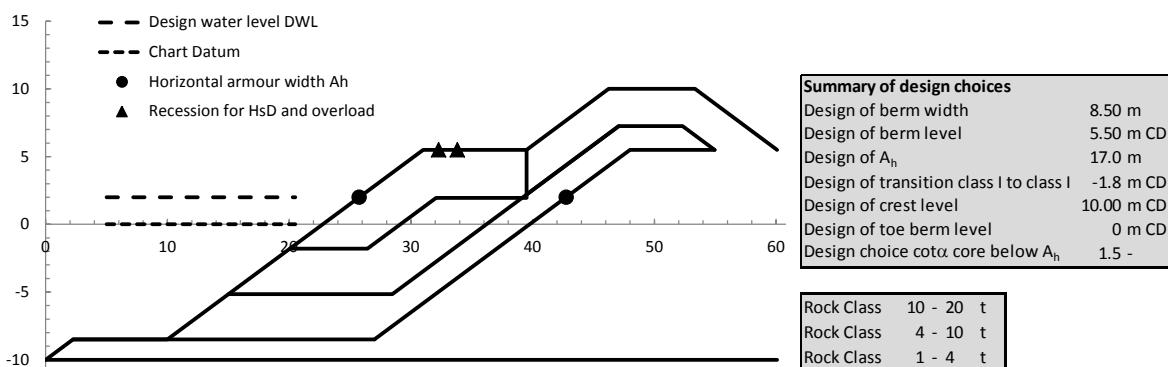

Figure 3: Calculated cross-section for $H_{sD} = 5$ m and Class I = 10-20 t.

The wanted resiliency is taken at 15% reshaping. The allowable overtopping $q = 1$ l/s per m for the 100-years event and $q = 10$ l/s per m for the overload. This is quite strict for the 100-years condition and if the rock on the crest would be large enough, close to Class I, the allowable overtopping could be raised a little. Finally, the mass density seawater is $\rho_w = 1025$ kg/m³ and of rock $\rho_r = 2700$ kg/m³.

Figure 3 should be reviewed to come to a final design of the cross-section. In this paper the experience with design and construction of berm breakwaters has been used to make this review. Figure 4 shows the final outcome and is of course quite close to the draft cross-section. The geometry of the Class I rock remains the same: a 3.5 m thick layer on the berm and down to -1.8 m CD at the seaward slope. In order to save a little Class II rock below the large Class I rock, also here a two diameter thick layer was taken (2.7 m thick). Another measure was to change the slope of the core to 1:2, which uses less Class III rock.

The water depth is too small to design a higher toe berm and therefore only a layer of 1.5 m core extends as an apron. In this example in Figure 4 the breakwater protects a quay area. Therefore the core of the crest terminates at the quay level.

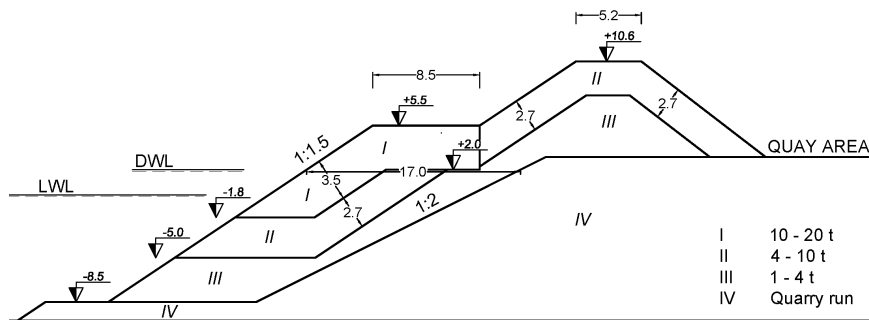

Figure 4: Hardly Reshaping Icelandic-type berm breakwater cross-section designed for $H_{sD} = 5.0$ m, Class I 10-20 t, $q_{100y} = 1$ l/s per m.

An allowable overtopping discharge of only 1 l/s per m in the 100-years design condition is quite strict. Figure 5 shows the lowering of the crest by about 2 m if 10 l/s per m could be tolerated. One should however realise that for the overload condition, the overtopping would increase to about 100 l/s per m, certainly significant overtopping.

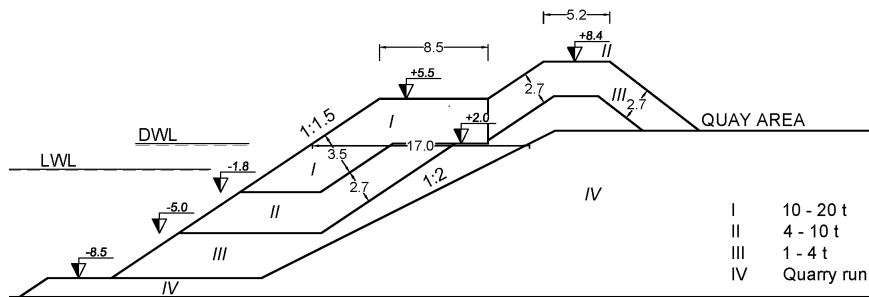

Figure 5: Hardly Reshaping Icelandic-type berm breakwater cross-section designed for $H_{sD} = 5.0$ m, Class I 10-20 t, $q_{100y} = 10$ l/s per m.

PR IC standard gradings, Class I 6-10 t

The hydraulic design conditions are similar to the ones in the previous section, only the rock classes have been changed. For completeness a short summary of these conditions is given here. All input and calculated values, including design choices, are given in the spreadsheet in Appendix D of Van der Meer and Sigurdarson (2016).

$H_{sD} = 5.0$ m $s_{op} = 0.03$ $T_p = 10.3$ s Overload $H_s = 6.0$ m Tidal range 0 m to + 1 m CD
 DWL = +2 m CD Safety $\Delta w = 1$ m above + 1 m CD Seabed at -10 m CD

The stability number is calculated as $H_s/\Delta D_{n50} = 2.13$, for a Class I of 6-10 t, which indeed gives a partly reshaping berm breakwater. For this Class I from standard gradings, one can choose connecting classes also from standard gradings, as Class II = 3-6 t and Class III = 1-3 t, all given in Table 2. The three classes are given in Figure 6.

The wanted resiliency is taken at 30% reshaping, which is the middle of the proposed range. The allowable overtopping $q = 1$ l/s per m for the 100-years event and $q = 10$ l/s per m for the overload. Finally, the mass density of seawater is $\rho_w = 1025$ kg/m³ and of rock $\rho_r = 2700$ kg/m³, similar to the previous example. Figure 6 shows the outcome of the calculations.

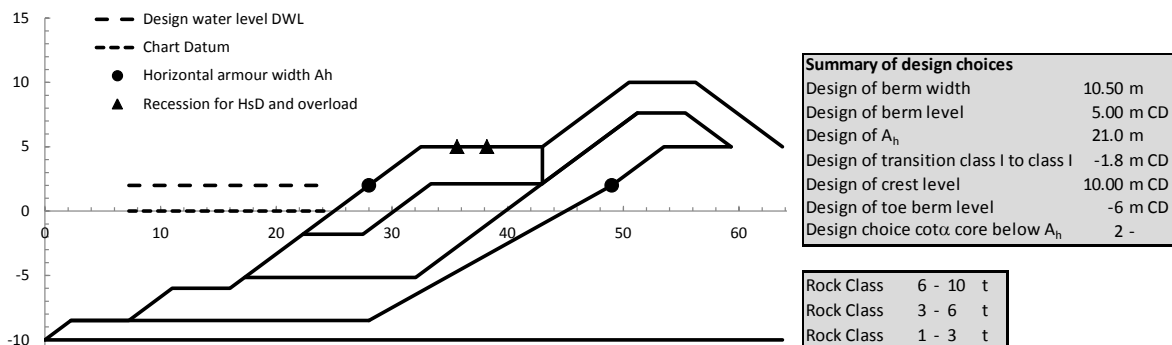

Figure 6: Calculated cross-section for $H_{sD} = 5$ m and Class I = 6-10 t.

The Class III rock of 1-3 t is still quite large compared to the wave conditions and this rock can be used to make a higher toe berm. The calculations (Appendix D – Van der Meer and Sigurdarson (2016)) give a highest toe level of -5.16 m CD and a level of -6 m CD has been chosen. The transition of Class I to Class II rock on the seaward side was chosen at -1.8 m CD.

The expected reshaping in Figure 6 is given by the triangles, the left one by the design conditions, the right one by overload conditions. The erosion profile should start in these points and will show a S-shaped curve, which crosses the original lower slope just below the water level. The triangles in Figure 6 suggest that the erosion profile might also take a part of the Class II rock below, certainly for the overload conditions. For this reason the final design, as given in Figure 7, shows a seaward layer

thickness of three stones, i.e. 4.3 m. Also the Class II layer underneath this layer has a thickness of three stones: 3.6 m.

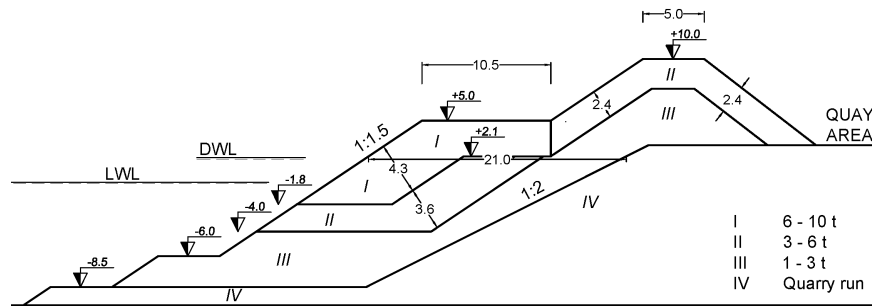

Figure 7: Partly Reshaping Icelandic-type berm breakwater cross-section designed for $H_{sD} = 5.0$ m, Class I 4-10 t, $q_{100y} = 1$ l/s per m.

FR MA standard gradings, Class I 3-6 t

The hydraulic boundary conditions in this example are similar to the ones in the two previous examples. A short summary of these conditions is repeated here. All input and calculated values, including design choices, are given in the spreadsheet in Appendix D of Van der Meer and Sigurdarson (2016).

$H_{sD} = 5.0$ m $s_{op} = 0.03$ $T_p = 10.3$ s Overload $H_s = 6.0$ m Tidal range 0 m to + 1 m CD
 DWL = +2 m CD Safety $\Delta w = 1$ m above + 1 m CD Seabed at -10 m CD

The stability number is calculated as $H_s/\Delta D_{n50} = 2.58$, for a Class I of 3-6 t, which indeed gives a fully reshaping berm breakwater. Originally a mass-armoured berm breakwater would have one large Class I rock with a wide gradation, for example 1-6 t. The stability number would then become $H_s/\Delta D_{n50} = 2.81$, still in the range of a fully reshaping berm breakwater, but with more recession of the berm. It is always an advantage to split the wide gradation into two gradings, in this case standard gradings of 3-6 t (Class I) and 1-3 t (Class II). The classes and cross-section are given in Figure 8.

The wanted resiliency is taken at 50% reshaping, which is 20% less than the maximum of 70%. The allowable overtopping $q = 1$ l/s per m for the 100-years event and $q = 10$ l/s per m for the overload. Finally, the mass density seawater is $\rho_w = 1025$ kg/m³ and of rock $\rho_r = 2700$ kg/m³, similar to the previous examples. Figure 8 shows the outcome of the calculations.

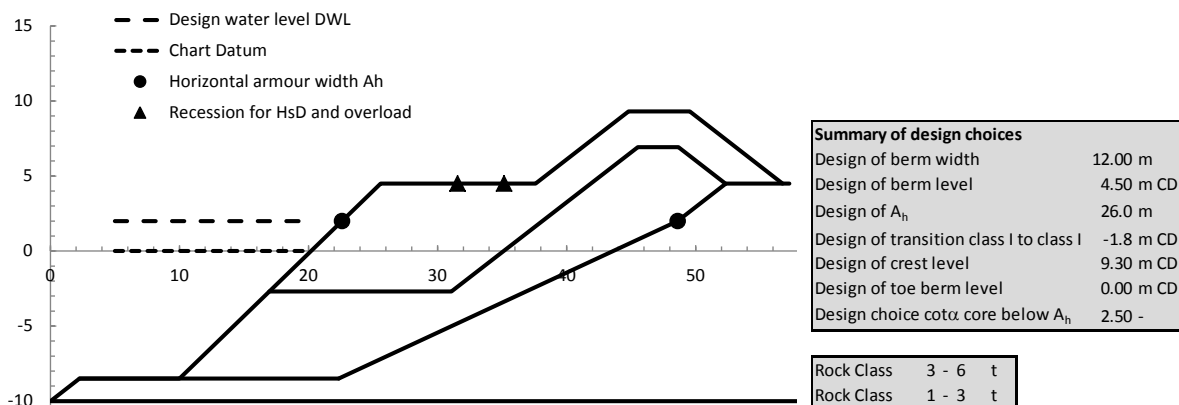

Figure 8: Calculated cross-section for $H_{sD} = 5$ m and Class I = 3-6 t.

Figure 8 shows two details that need a better look. First of all, despite a resiliency of 50%, the recession of the overload condition (the right hand triangle in the graph) is quite close to the edge with the upper slope. This means that under overload conditions almost the complete berm would reshape. Secondly, the horizontal armour width of 26 m with only a berm width of 12 m, gives a situation where the large rock extends far under the crest of the structure. Both observations lead to the conclusion that enlarging the berm width (or similarly: shifting the crest landward) would be a good option. Figure 9 shows the final design with a berm width of 14 m.

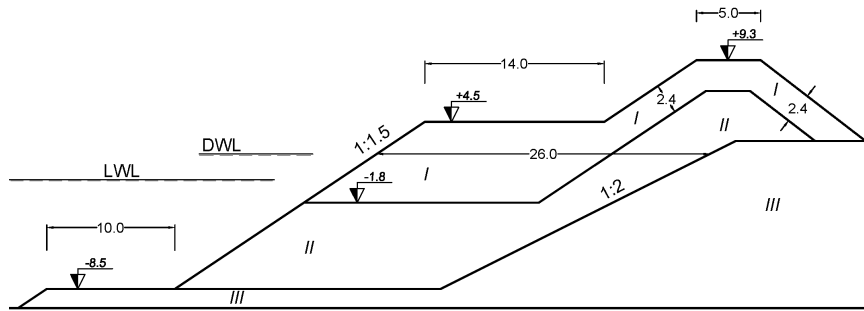

Figure 9: Fully Reshaping Mass-armoured berm breakwater cross-section designed for $H_{sD} = 5.0$ m, Class I 1-10 t, $q_{100y} = 1$ l/s per m.

Conventional rock armour design

With a design wave height of 5 m, as in the previous sections, and a fairly large rock grading like 6-10 t, it is also possible to design a conventional rock armour protection. Such a design can then be compared with, for instance, the partly reshaping Icelandic-type berm breakwater that is described in one of the sections above. That example has a Class I rock of 6-10 t.

The design conditions are given with a peak period of $T_p = 10.3$ s. Assuming a relationship of $T_p = 1.2T_m$, gives a mean period of $T_m = 8.6$ s. The peak of the storm is assumed to give 3000 waves, which is a little over 7 hours. The Van der Meer formulae (Van der Meer (1988)) can be used to calculate the damage level, S_d , for several wave conditions. Figure 10 gives the damage curves for three mean wave periods, as calculated by these formulae.

The rock slope that was chosen was 1:2.5. A steeper slope would probably give too much damage. A gentler slope, like 1:3, would give less damage. Figure 10 also shows the design condition (100-years) and the overload condition. The design condition gives $S_d = 3.4$ and the overload condition gives $S_d = 6.8$. For a slope of 1:2.5 an allowable damage for a 100-years condition would be between $S_d = 2-4$. For an overload condition the damage should not exceed $S_d = 10$. Both conditions are met, which means that a slope 1:2.5 with a 6-10 t armour layer would be able to withstand the given wave conditions.

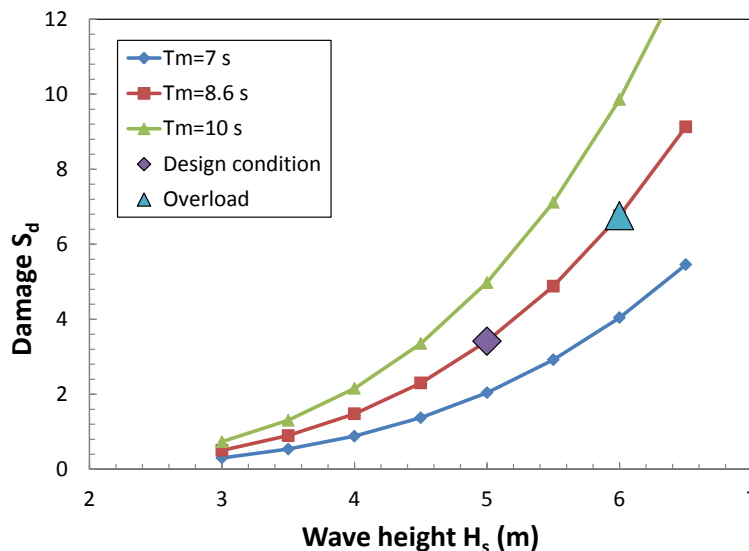

Figure 10: Damage curves for a conventional rock slope with an armour layer of 6-10 t; $cota = 2.5$; $P = 0.4$; $N = 3000$

Figure 10 also shows the influence of the wave period. This influence is insignificant for berm recession of a berm breakwater, but is significant for a conventional armour layer of rock. A smaller wave period than the design period will clearly give less damage. But the damage increases quite rapidly if the mean period increases from $T_m = 8.6$ s to 10 s. The damage increases to $S_d = 5.0$ for the

design condition and $S_d = 9.9$ for the overload condition. For a good design of this conventional structure, one should look at the range of wave periods that will be possible. If indeed $T_m = 10$ s would be possible for design conditions, one should modify the slope angle to 1:3 in order to make the structure more stable. In this example a slope of 1:2.5 is taken for design.

The underlayer is normally $1/10^{\text{th}}$ to $1/15^{\text{th}}$ of the armour mass. This leads to a standard grading of 300-1000 kg. The rock armour layer has a nominal diameter of $D_{n50} = 1.44$ m, which gives a layer thickness of 2.9 m. The underlayer has a nominal diameter of $D_{n50} = 0.62$ m, which gives consequently a layer thickness of 1.25 m.

The required crest height can be calculated with the formulae in EurOtop (2016). A conventional rock armour on an underlayer has a roughness factor of $\gamma_f = 0.40$. For the design conditions with $H_s = 5.0$ m and an allowable overtopping discharge of 1 l/s per m, a crest freeboard is required of 7.45 m. With a design water level of +2 m CD, the required crest height for this condition becomes 9.45 m CD. With the overload condition with $H_s = 6.0$ m and an allowable overtopping discharge of 10 l/s per m, the required crest freeboard becomes $R_c = 7.2$ m. This is lower than the 7.45 m for the design condition, which means that the crest height can be determined at 9.5 m CD.

The cross-section is given in Figure 11 and can be compared with the partly reshaping berm breakwater in Figure 7. Both structures are fit for purpose. A difference might be that the resiliency of the berm breakwater is larger than for the conventional structure, as after the overload condition still half of the berm is left, where the armour layer of the conventional structure will be close to "underlayer visible". But both structures can cope with such an overload condition.

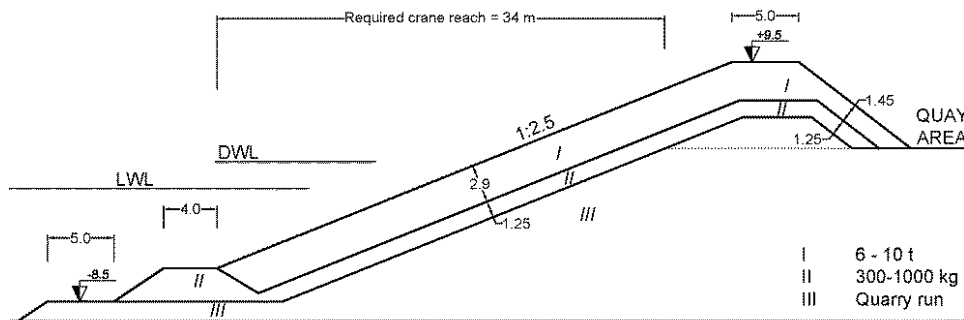

Figure 11: Conventional rock armoured structure with 6-10 t on a slope of 1:2.5. Design for $H_{SD} = 5$ m and $q_{100y} = 1$ l/s per m.

Figure 12 shows direct comparisons of the two cross-sections, where the conventional structure has been given in blue and the berm breakwater in red. The volume of large rock 6-10 t in the conventional design is more than twice of that in the berm breakwater (Class I). Of course the total volume of rock larger than 1 t is larger for the berm breakwater, but the use of the largest rock class is much smaller. In case the largest rock class is not easy to produce, the berm breakwater design gives an advantage. The total volumes of the cross-sections of both designs are quite similar, both around 460-480 m^3 per m length.

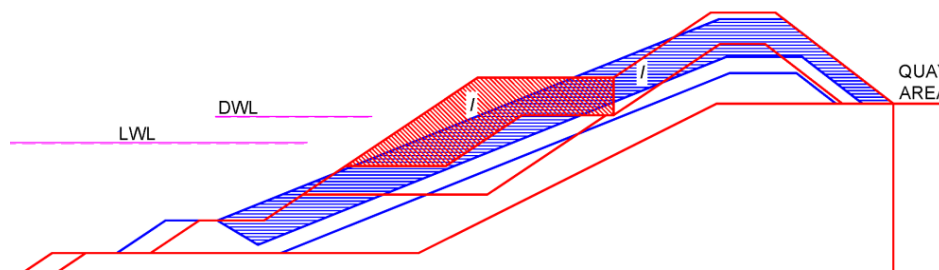

Figure 12: Direct comparison of cross-sections of the conventional breakwater and the berm breakwater

All rock on the berm breakwater of Figure 7 can be placed by excavator. This will be much more difficult for the conventional design, as the largest rock near the toe need a crane reach of about 34 m or placement from marine plant.

Overall conclusions and comparison of examples for a design wave height of 5 m

Above sections give four designs of rock structures that can cope with a 100-years design wave height of 5 m. They are all fit for purpose. In all cases the crest level is around 10 m CD, allowing about 1 l/s per m wave overtopping. The main difference is the rock size of Class I on the seaward side and the volume of this largest rock class. A Class I of 10-20 t is of course a very large rock class, but the volume needed with respect to the total volume is quite limited, see Figure 5. The largest volume of rock for the breakwater is found for the fully reshaping berm breakwater, see Figure 8. But now the largest rock class is only 3-6 t. The difference between the berm breakwater designs is the resiliency. The smallest stability number, or largest rock size for Class I, gives the best resiliency. Even after overload conditions there is a large remaining capacity for severe wave action if the structure is only hardly reshaping. From that point of view one should always try to design for the largest rock class that can be made available.

The conventional structure in Figure 10 has a long 1:2.5 slope with 6-10 t rock. The armour layer cannot be constructed by excavator, but needs a crane with a long reach. Total rock usage is comparable with the berm breakwater with Class I rock of 6-10 t (Figure 8), but the need for the large 6-10 t rock is more than twice for the conventional design. This conventional design is more vulnerable for (longer) wave periods, which is not the case for a berm breakwater.

EXAMPLES FOR A DESIGN WAVE HEIGHT OF 3 M

HR IC dedicated quarry, Class I 1-4 t

The design condition is a design wave height of $H_{sD} = 3.0$ m with a fairly low wave steepness of $s_{op} = 0.02$, giving $T_p = 9.8$ s. The overload condition is 20% higher than the design condition, giving $H_s = 3.5$ m at the design water level DWL. Tides range between 0 m CD to +1 m CD (1 m tidal range). The design water level (100-years condition) is at the same level as the maximum tide = +1 m CD. Daily waves are quite moderate and a safety margin of $\Delta w = 1$ m above MHWs will be enough for construction. A more or less flat foreshore is present and at the toe of the structure the seabed is present at -9 m CD. All input and calculated values, including design choices, are given in the spreadsheet in Appendix D of Van der Meer and Sigurdarson (2016).

The allowable overtopping $q = 5$ l/s per m for the 100-years event and $q = 20$ l/s per m for the overload. Finally, the mass density seawater is $\rho_w = 1025$ kg/m³ and of rock $\rho_r = 2600$ kg/m³.

Note that design conditions described above, the allowable overtopping conditions, as well as the mass densities of sea water and rock may differ from the conditions assumed in the earlier section with a design wave height of 5 m. On one hand this makes direct comparison between the solutions for design wave heights of 3 m and 5 m not straight forward (within the section they are comparable), but on the other hand it shows reality, where these conditions vary.

The wanted resiliency is taken at 20% reshaping, which is the upper value of the proposed range. The stability number is calculated as $H_s/\Delta D_{n50} = 1.98$, for a class I of 1-4 t, which indeed gives a partly reshaping berm breakwater. For this class I from a dedicated quarry, one can choose Class II = 0.2-1 t, both classes are given in Table 2. Only two rock classes are needed for this mild wave climate and the calculated cross-section is given in Figure 13.

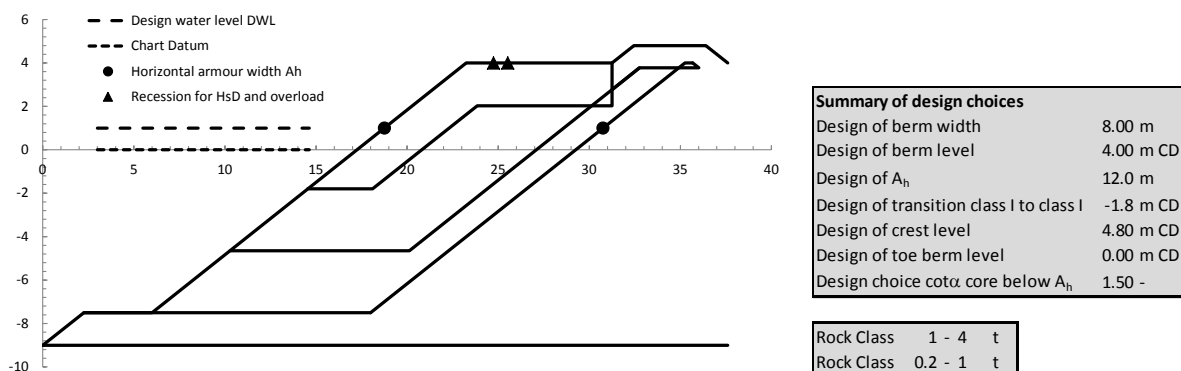

Figure 13. Calculated cross-section for $H_{sD} = 3$ m and Class I = 1-4 t.

The “standard” cross-section from the spreadsheet gives a berm breakwater with three rock classes, as in Figure 13. Actually, one should only look at the Class I layer, as the underlying material in the berm will all be Class II 0.2-1 t rock. A high toe berm has no function for a hardly reshaping berm breakwater and therefore a high toe berm has not been designed.

The berm level is higher than $0.6H_{SD}$, as the berm level follows from the construction issue that it should be constructed from the underlying Class II rock on a safe working level. But as the Class I rock is not heavy and distances to reach not very far, it may also be possible to construct the Class I rock with an excavator from the core. In that case the berm level can be lowered to roughly +2.8 m CD, instead of +4.0 m CD as in the final design given in Figure 14. Another option is to raise the crest level a little and have less wave overtopping at marginal costs.

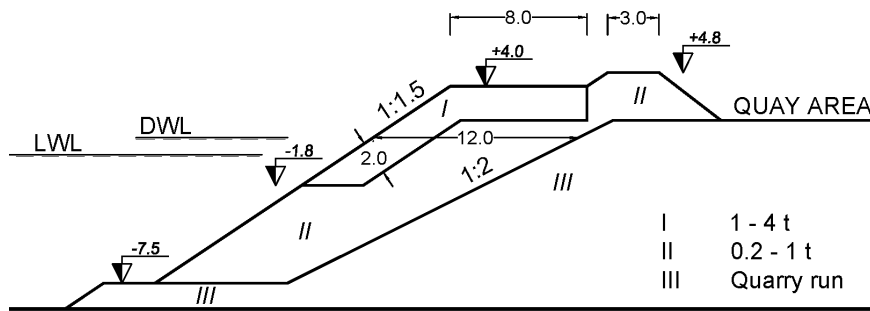

Figure 14. Hardly Reshaping Icelandic-type berm breakwater cross-section designed for $H_{SD} = 3.0$ m, Class I 1-4 t, $q_{100y} = 5$ l/s per m.

PR MA dedicated quarry, Class I 0.5-2 t

The wave conditions are similar to the example in the previous section. A short summary of these conditions is repeated here. All input and calculated values, including design choices, are given in the spreadsheet in Appendix D of Van der Meer and Sigurdarson (2016).

$H_{SD} = 3.0$ m $s_{op} = 0.02$ $T_p = 9.8$ s Overload $H_s = 3.5$ m Tidal range 0 m CD to + 1 m CD
 DWL = +2 m CD Safety $\Delta w = 1$ m above + 1 m CD Seabed at -9 m CD

The design is a partly reshaping mass-armoured berm breakwater. The wanted resiliency is taken at 30% reshaping, which is the middle value of the proposed range. The stability number is calculated as $H_s/\Delta D_{n50} = 2.49$, for a Class I of 0.5-2 t, which indeed gives a partly reshaping berm breakwater, but it is very close to fully reshaping. For this Class I from a dedicated quarry, one can choose Class II = 100-500 kg, both classes are given in Table 2. The mass-armoured breakwater has two rock classes and the calculated cross-section is given in Figure 15.

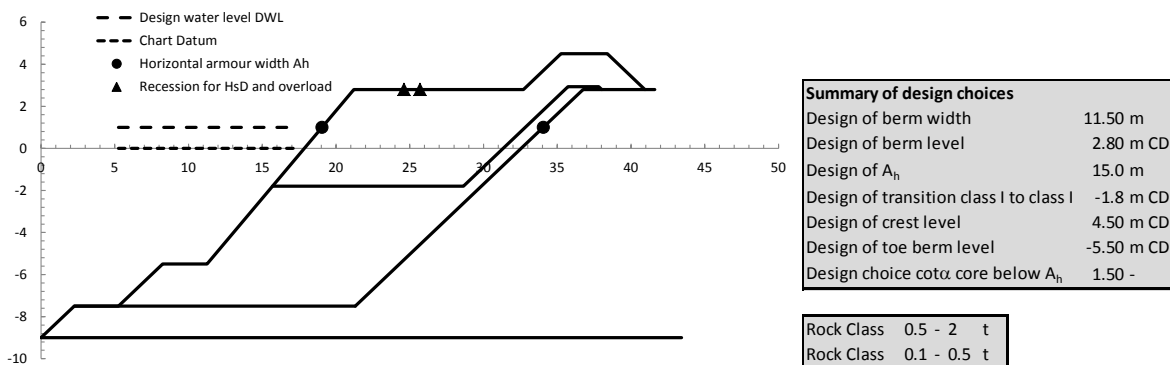

Figure 15. Calculated cross-section for $H_{SD} = 3$ m and Class I = 0.5-2 t.

A high toe berm has a positive function for a partly reshaping berm breakwater and therefore a high toe berm at -5.5 m CD has been designed. As for the design in the previous section, the berm level is higher than at $0.6H_{SD}$. The final design is given in Figure 16.

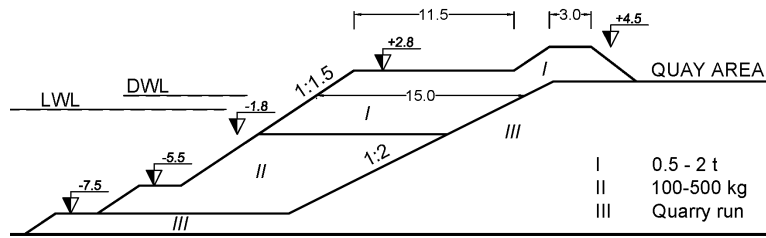

Figure 16. Partly Reshaping Mass-armoured berm breakwater cross-section designed for $H_{SD} = 3.0$ m, Class I 0.5-2 t, $q_{100y} = 5$ l/s per m.

Conventional rock armour design

A design wave height of only 3 m is quite mild and a conventional rock armoured structure can certainly be designed without needing too large rock. Damage curves have been calculated in a similar way as for Figure 10. First a rock armour of 1-4 t has been chosen, similar to the berm breakwater design described above, see Figure 17. A slope angle of 1:2.5 is needed for a stable design. This would result in a similar cross-section as in Figure 11, although with smaller rock.

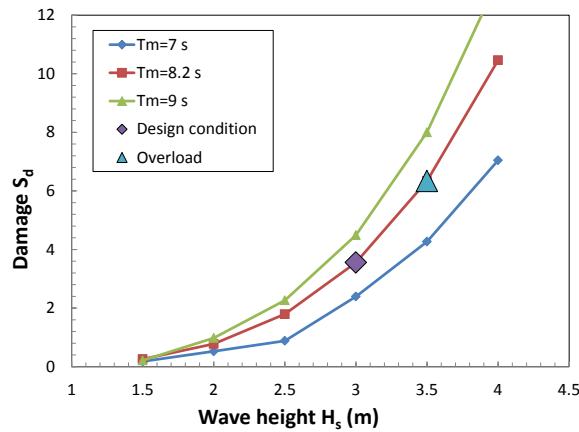

Figure 17. Damage curves for a conventional rock slope with an armour layer of 1-4 t; $\cot\alpha = 2.5$; $P = 0.4$; $N = 3000$.

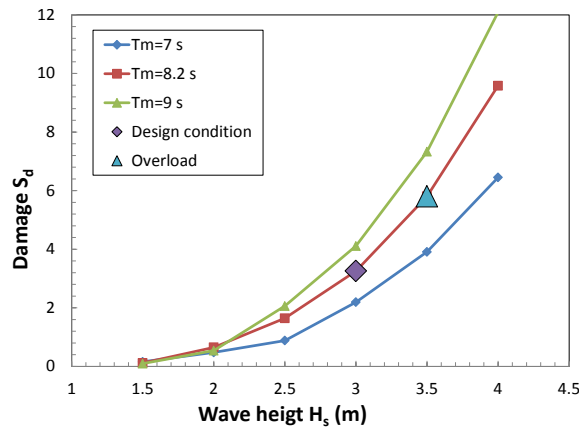

Figure 18. Damage curves for a conventional rock slope with an armour layer of 3-6 t; $\cot\alpha = 1.75$; $P = 0.4$; $N = 3000$.

A 1-4 t rock grading is not a very large grading. In order to overcome the problem with construction of a gentle slope (long crane or excavator reach) it is also possible to consider a slightly larger rock class, for example 3-6 t, which is also a standard grading. Figure 18 gives similar damage curves as specified in Figure 17, but the rock grading is now 3-6 t and the slope angle required now becomes 1:1.75. This is almost as steep as the seaward slope of the berm breakwaters. An underlayer that will

be acceptable, although a little on the small side with respect to the general rule of $1/10^{\text{th}}$ to $1/15^{\text{th}}$ of the armour layer mass, is 100-300 kg. A standard grading of 300-1000 kg would be too large for an armour layer of 3-6 t. An overtopping discharge of 5 l/s per m is reached for a crest freeboard of 3.45 m. Together with the design water level of +1 m CD, this gives a crest level of +4.5 m CD. This is even a little lower than the +4.8 m CD that is needed for a berm breakwater with 1-4 t rock, see Figure 13. A possible cross-section is shown in Figure 19.

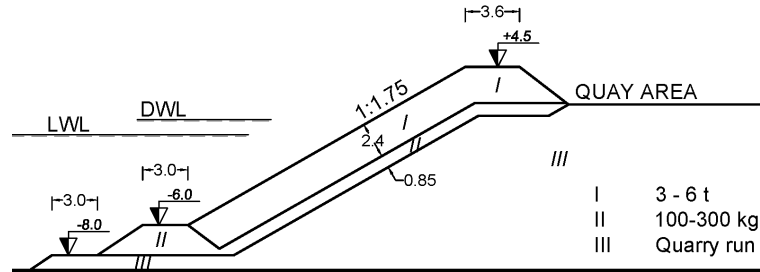

Figure 19. Conventional rock armoured structure with 3-6 t on a slope of 1:1.75.
Design for $H_{sD} = 3$ m and $q_{100y} = 5$ l/s per m.

The design of the cross-section in Figure 19 can be compared with the berm breakwater design in Figure 14, see Figure 20. The conventional design has a slightly larger armour rock, 3-6 t instead of Class I 1-4 t. The volume of large rock for the conventional design is still significantly larger than for the Class I rock: 63 m^3 per m length against 33 m^3 per m length. But the total volume of rock, taken seaward from the quay area, is larger for the berm breakwater (346 m^3 per m length) than for the conventional design (275 m^3 per m length). The slope of the conventional design is quite steep and the reach needed to place the lowest large rock is not too large. It can possibly be done by a large excavator.

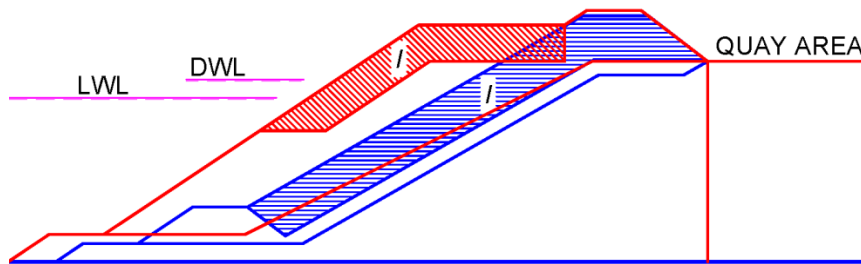

Figure 20. Comparison of conventional cross-section with a berm breakwater design.

Overall, the conventional design needs slightly larger rock, but the total volume of rock is substantially less than for the berm breakwater design. Both structures can easily be constructed.

Overall conclusions and comparison

A design wave height of $H_{sD} = 3$ m can be considered as a mild wave climate and a conventional design with a relatively steep slope of 1:1.75 and rock of 3-6 t is well able to resist such a wave climate. If a berm breakwater is designed, quite small rock is sufficient to make a proper design: a hardly reshaping berm breakwater comes to Class I of 1-4 t rock and a partly reshaping berm breakwater to only 0.5-2 t rock.

The usage of armour rock of a conventional design, compared to Class I of a berm breakwater, is always significantly larger (roughly a factor of 2). But the total volume of rock in this case of a mild wave climate (and relatively steep slope) is significantly less for the conventional design.

If rock of 3-6 t can be produced, then a conventional design as in Figure 19, may well be cheaper than a berm breakwater design like in Figure 14 or Figure 16. Only if this kind of rock cannot be achieved, one can think of a berm breakwater with smaller rock.

This leads to the conclusion that if armour rock is readily available for a conventional design with a steep slope, then a berm breakwater may not be a cheaper solution depending on the price difference

between the different rock classes. A berm breakwater may be more attractive if a conventional design leads to too large rock (in large quantities) and with a gentle slope. Such a berm breakwater also needs large rock, but in a much smaller quantity (just Class I rock), and construction will be easier.

EXAMPLES FOR DESIGN A WAVE HEIGHT OF 7 M

HR IC dedicated quarry, Class I 20-35 t

The design condition is a quite severe design wave height of $H_{sD} = 7.0$ m with $s_{op} = 0.04$, giving $T_p = 10.6$ s. The overload condition is 15% higher than the design condition, giving $H_s = 8.0$ m at the design water level DWL. This overload percentage is a little lower than in previous sections and in real design may depend on the steepness of the curve of the extreme wave climate. Tides range between 0 m CD to + 2 m CD (2 m tidal range). The design water level (100-years condition) = surge + maximum tide = +4 m CD. Daily waves are quite moderate and a safety margin of $\Delta w = 1$ m above MHWS will be enough for construction. The foreshore is flat at -18 m CD. All input and calculated values, including design choices, are given in the spreadsheet in Appendix D of Van der Meer and Sigurdarson (2016).

The wanted resiliency is taken at 20% reshaping, which is the upper value for the range of hardly reshaping berm breakwaters. The allowable overtopping $q = 10$ l/s per m for the 100-years event and no restriction is given for the overload. This means that very significant overtopping is allowed with large overtopping volumes. One should design the crest and specifically the rear slope accordingly and physical model testing is a must in this case, to check the stability of the rear slope for overtopping waves. The crest level is only calculated for the 100-years condition and becomes 12.5 m CD. Finally, the mass density of seawater is $\rho_w = 1,030$ kg/m³ and of rock $\rho_r = 2,700$ kg/m³.

A Class I of 20-35 t is a very heavy rock grading, far beyond standard gradings. It needs a dedicated armourstone production with specific care in quarry yield production and blasting design. But these kinds of rock gradings have been produced in the past. Guidance is given in Van der Meer and Sigurdarson (2016).

For a Class I of 20-35 t one can choose connecting classes as Class II = 10-20 t, Class III = 4-10 t and a Class IV = 1-4 t, all given in Table 2. The stability number is calculated as $H_s/\Delta D_{n50} = 1.99$ for a Class I of 20-35 t, which indeed gives a hardly reshaping berm breakwater, but very close to a partly reshaping one (the transition is at $H_s/\Delta D_{n50} = 2.0$). The cross-section as calculated by the spreadsheet is given in Figure 21.

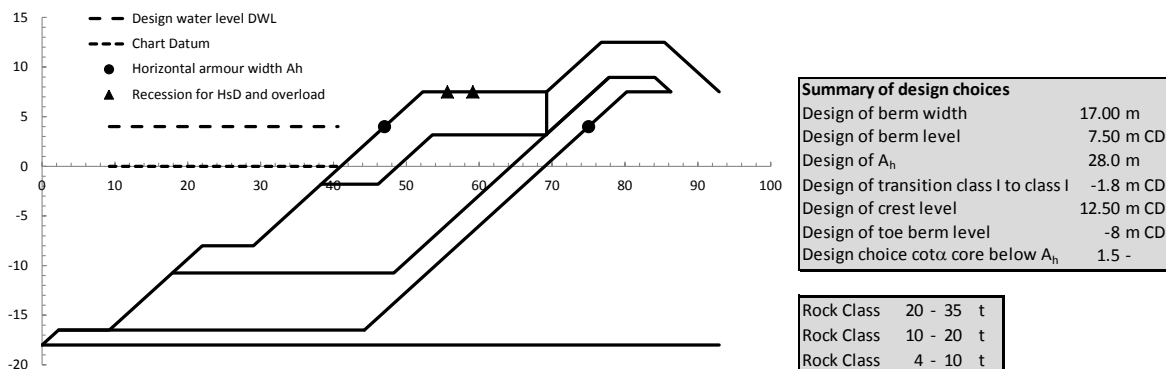

Figure 21. Calculated cross-section for $H_{sD} = 7$ m and Class I = 20-35 t.

The graph shows only three rock classes and not four (the spreadsheet gives only three classes). The geometry of Class I is as calculated, the other classes have to be distributed over the cross-section and this has been done in the final design in Figure 22. For a hardly reshaping berm breakwater, there is quite some expected recession of the berm, certainly for the overload condition, see Figure 21. This is due to the fact that the structure is close to a partly reshaping berm breakwater.

A toe berm has been designed at a level of -8 m CD, with Class III of 4-10 t as grading. For a hardly reshaping berm breakwater a toe berm is not necessary, but the structure is close to partly reshaping and displaced rock will fall onto the toe berm. Finally this will limit the amount of recession a little.

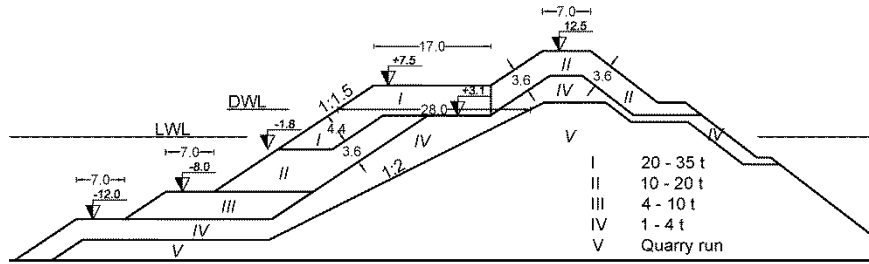

Figure 22. Hardly Reshaping Icelandic-type berm breakwater cross-section designed for $H_{SD} = 7.0$ m, Class I 20-35 t, $q_{100y} = 10$ l/s per m.

PR IC dedicated quarry, Class I 10-20 t

The design conditions are similar to the previous example. A short summary of these conditions is repeated here. All input and calculated values, including design choices, are given in the spreadsheet in Appendix D of Van der Meer and Sigurdarson (2016).

$H_{SD} = 7.0$ m $s_{op} = 0.04$ $T_p = 10.6$ s Overload $H_s = 8.0$ m Tidal range 0 m CD to + 2 m CD
 DWL = +4 m CD Safety $\Delta w = 1$ m above + 2 m CD Seabed at -18 m CD

The wanted resiliency is taken at 30% reshaping, which is the middle value for the range of partly reshaping berm breakwaters. The allowable overtopping is similar to the previous section: $q = 10$ l/s per m for the 100-years event and no restriction is given for the overload. The crest level is only calculated for the 100-years condition and becomes 12.5 m CD, similar to the previous example. A Class I of 10-20 t is a heavy rock grading, beyond standard gradings. It needs a dedicated armourstone production with specific care in quarry yield production and blasting design. But these kinds of rock gradings have been produced in the past. Guidance is given in Van der Meer and Sigurdarson (2016).

For a Class I of 10-20 t one can choose connecting classes as Class II = 4-10 t and a Class III = 1-4 t, all given in Table 2. The stability number is calculated as $H_s/\Delta D_{n50} = 2.44$ for a Class I of 10-20 t, which indeed gives a partly reshaping berm breakwater, but quite close to a full reshaping one (the transition is at $H_s/\Delta D_{n50} = 2.5$). The cross-section as calculated by the spreadsheet is given in Figure 23.

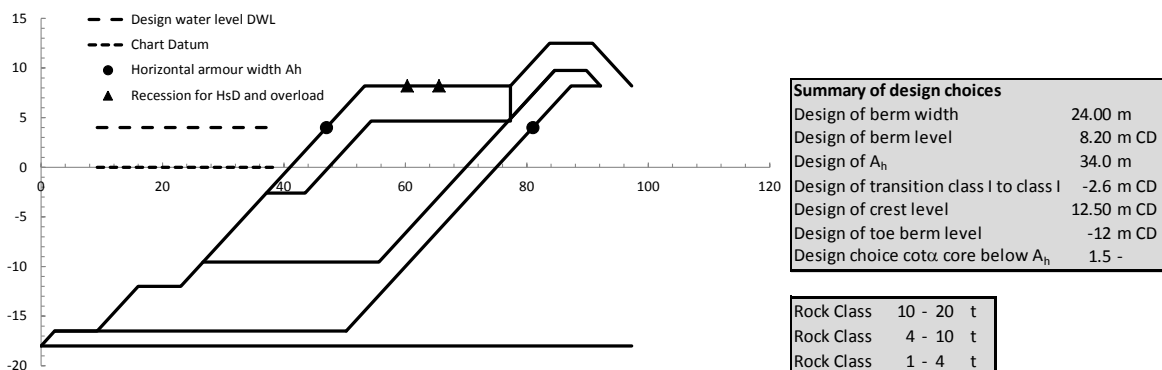

Figure 23. Calculated cross-section for $H_{SD} = 7$ m and Class I = 10-20 t.

The graph shows the three rock classes. The final design is shown in Figure 24. There is quite some expected recession of the berm, certainly for the overload condition, see Figure 23. It means that reshaping of the berm may well cut into the Class II rock underneath. In order to avoid that the thickness of the seaward side layer of 10-20 t should be increased, see the final design in Figure 24.

A toe berm has been designed at a level of -12 m CD, with Class III of 1-4 t as grading. This will limit the amount of recession a little. It is also possible to design a toe berm at -8 m CD, as in the previous example, but then the toe berm should be constructed of 4-10 t rock, which is Class II rock. In the final design the first choice has been made.

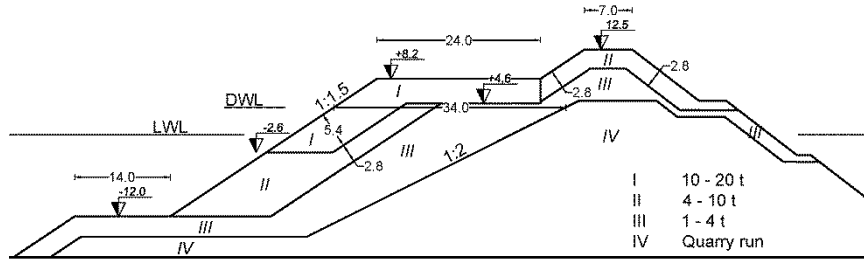

Figure 24. Partly Reshaping Icelandic-type berm breakwater cross-section designed for $H_{SD} = 7.0$ m, Class I 10-20 t, $q_{100y} = 10$ l/s per m.

FR MA standard grading, Class I 6-10 t

The design conditions are similar to the previous two examples. A short summary of these conditions is repeated here. All input and calculated values, including design choices, are given in the spreadsheet in Appendix D of Van der Meer and Sigurdarson (2016).

$H_{SD} = 7.0$ m $s_{op} = 0.04$ $T_p = 10.6$ s Overload $H_s = 8.0$ m Tidal range 0 m CD to + 2 m CD
 DWL = +4 m CD Safety $\Delta w = 1$ m above + 2 m CD Seabed at -18 m CD

The wanted resiliency is taken at 50% reshaping, which is 20% lower than the upper value for the range of fully reshaping berm breakwaters. The allowable overtopping is again $q = 10$ l/s per m for the 100-years event and no restriction is given for the overload. The crest level is only calculated for the 100-years condition and becomes 12.5 m CD, similar to the previous example with Class I of 10-20 t. As this is a fully reshaping mass-armoured berm breakwater, it is possible to use Equation 9 in Van der Meer and Sigurdarson (2014) to check the stability of the rear side. For the overload condition $R_c/H_s \cdot s_{op}^{1/3} = 0.36$, which still is well above the critical level of 0.21 that stands for start of damage. This means that a grading of 3-6 t over the crest and the rear side would be applicable.

In contrast to the two previous examples, the Class I grading of 6-10 t is a standard grading. The proposed mass-armoured berm breakwater has two classes and one can choose a connecting class as Class II = 3-6 t, both given in Table 2. If both gradings would be combined it results in a class 3-10 t, which is a kind of class that was used for the early designed fully reshaping mass-armoured berm breakwaters.

The stability number is calculated as $H_s/\Delta D_{n50} = 3.01$ for a Class I of 6-10 t, which is really at the upper limit for fully reshaping mass-armoured berm breakwaters, as the transition is at $H_s/\Delta D_{n50} = 3.0$. The cross-section as calculated by the spreadsheet is given in Figure 25. As the stability number is very high, there is a lot of berm reshaping, with quite big rock. One should use only good quality rock in this case.

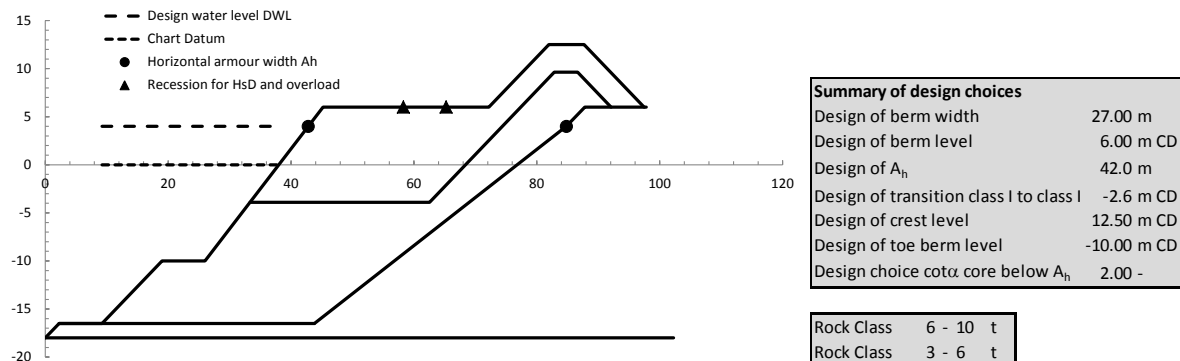

Figure 25. Calculated cross-section for $H_{SD} = 7$ m and Class I = 6-10 t.

A toe berm has been designed at a level of -10 m CD, with Class II of 3-6 t as grading. This will limit the amount of recession. The spreadsheet gives a standard toe berm width of one wave height (7 m), but given the expected recession of the berm it might be better to increase the width to about 10 m. In order to reduce the volume of 3-6 t rock it is also possible to use more core berm. This is the area drawn with dashed lines in the final design as given in Figure 26.

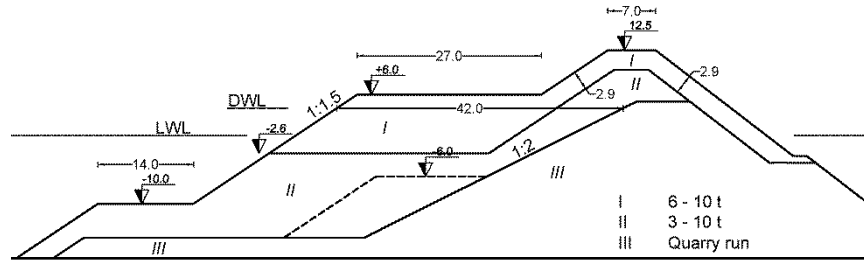

Figure 26. Fully Reshaping mass-armoured berm breakwater cross-section designed for $H_{SD} = 7.0$ m, Class I 6-10 t, $q_{100y} = 10$ l/s per m.

Overall conclusions and comparison

It is hardly possible to design a conventional rock armour layer for a wave climate with a design wave height of 7 m. From a stability point of view, it is only possible with the largest standard grading of 10-15 t in the Rock Manual (2007) and a gentle slope angle of 1:3.5. For a 10-20 t grading from a dedicated quarry, such a design still needs a slope angle of 1:3. For both examples it means that a crane is required with a reach of around 80-100 m that should place stones up to 20 t quite precisely in a double layer deep under water. Another option is to place the armour rock at the toe by barge, but that needs quite calm daily wave conditions to place the rock correctly.

Experience shows that conventional rock armoured structures with these large rock and with such gentle slopes have not been designed and constructed. The main reason is that in such a case one makes the choice to use concrete units on a much steeper slope.

But another option might of course be to design a berm breakwater, as was done in this paper. If indeed a Class I of 20-35 t can be obtained from a dedicated quarry, this design (Figure 22) is preferred as it gives the smallest total volume of rock and the largest resiliency. But a design with a Class I of 10-20 t (Figure 24) also gives a good design. A fully reshaping mass-armoured design can be made of rock from a dedicated quarry, but also from standard gradings with Class I of 6-10 t, as was done in Figure 26. In this case quite some recession will occur, which means that big rock is moving around from the berm downwards, with possible breakage of rock as a result. For this high design wave height of 7 m, a fully reshaping berm breakwater with only Class I rock of 6-10 t includes some (unknown) risks and if possible one should try to get a larger rock grading for the Class I rock.

"Rock" is the essential word in design of berm breakwaters. Often dedicated quarries can be found and opened to produce the required rock. This is different from designs with rock from existing quarries, where delivery of very large rock classes may be problematic. It has been proven possible to win really large rock in dedicated quarries and this experience has been described in Van der Meer and Sigurdarson (2016). Quarry and project management as well as blasting and sorting techniques are essential in getting all required rock for an acceptable price. With this experience it is possible to design and construct berm breakwaters for a design wave height of 7 m or even more.

Construction of dedicated Icelandic-type of berm breakwaters is still fairly easy with excavators of maximum 120 t, which can handle rocks up to 35 t. Heavier excavators will probably become available on the market so the future may well be that rock over 35 t can be used in construction.

REFERENCES

EurOtop (2007). Wave overtopping of sea defences and related structures – Assessment Manual. Allsop, N.W.H., Pullen, T., Bruce, T., Van der Meer, J.W., Schüttrumpf, H. and Kortenhaus, A., www.overtopping-manual.com.

EurOtop (2016). Manual on wave overtopping of sea defences and related Structures. An overtopping manual largely based on European research, but for worldwide application. Allsop, N.W.H., Bruce, T., De Rouck, J., Kortenhaus, A., Pullen, T., Schüttrumpf, H., Troch, P., Van der Meer, J.W. and Zanuttingh, B., www.overtopping-manual.com.

ROCK MANUAL (2007). The Rock Manual. The use of rock in hydraulic engineering, CIRIA, CUR, CETMEF.

SIGURDARSON, S. AND J.W. VAN DER MEER (2015). Design and construction of berm breakwaters. Proc. Coastal Structures 2015, ASCE, Boston.

SIGURDARSON, S., J.W. VAN DER MEER, E. BIJL, YANG SIHAN, TANG QIAOLIANG, ZHANG XIAOQIANG, JAMES KS GOH AND D. HEIJBOER (2014). Icelandic-type berm breakwater for the Hambantota artificial island revetment, application of geometrical design rules. Proc. 34th Conf. Coastal Eng., ASCE, Seoul.

SIGURDARSON, S. AND J.W. VAN DER MEER (2013). Design of berm breakwaters, recession, overtopping and reflection. Proc. ICE, Coasts, Marine Structures and Breakwaters 2013, Edinburgh.

SIGURDARSON, S. AND J.W. VAN DER MEER (2012). Wave overtopping at berm breakwaters in line with EurOtop. Proc. 33th Conf. Coastal Eng., ASCE, Santander.

VAN DER MEER, J.W. AND S. SIGURDARSON (2016). Design and Construction of Berm Breakwaters. World Scientific. Advanced Series on Ocean Engineering, Volume 40. ISBN 978-981-4749-60-2.

VAN DER MEER, J.W. AND S. SIGURDARSON (2014). Geometrical design of berm breakwaters, Proc. 34th Conf. Coastal Eng., ASCE, Seoul.

VAN DER MEER, J.W. (1988). Rock slopes and gravel beaches under wave attack, Doctoral thesis, Delft University of Technology.

VAN GENT, M.R.A. AND VAN DER WERF, I.M. (2014). Rock toe stability of rubble mound breakwaters, Coastal Eng., 83, pp. 166-176.